

H0111 Estación de Sabiñánigo - escala H0 (1:87)



Introducción
Despiece
Manual de montaje
Planos

H0111 Estación de Sabiñánigo (Norte) - escala H0

Introducción:

La estación fue inaugurada el 1 de junio de 1893 con la puesta en marcha del tramo Huesca-Jaca de la línea que pretendía unir Zaragoza con la frontera francesa por Canfranc. Aunque dicho tramo fue abierto y explotado desde un primer momento por Norte la concesión inicial había recaído en la Sociedad Anónima Aragonesa la cual cedió la misma a Norte.

En cuanto a la reproducción, cabe mencionar que se trata de un kit de moderada dificultad. donde encontrará diferentes tipos de materiales, aunque básicamente cartón de alta calidad de diferentes espesores. También algunas piezas impresas en tecnología 3D sobre PLA y tubos de aluminio.

Este manual se divide en los siguientes apartados:

- Introducción (esta sección)
- Despiece
- Manual de montaje
- Planos

Le recomendamos que lea completamente este manual antes de proceder al montaje.

Si quedan dudas al respecto, o desea realizar cualquier otra consulta, puede dirigirse a admin@parvus.info, y responderemos todas las cuestiones que desee plantearnos.

Por último le animamos a enviarnos fotografías del resultado, pasarán a formar parte de nuestra biblioteca de referencias montadas, si nos lo permite las publicaremos en las redes sociales y servirán, sin duda, para inspirar a futuros aficionados.

Parvus, Noviembre 2024

H0111 Sabiñánigo Station (North) - H0 scale

Introduction:

The station was inaugurated on 1st June 1893 with the opening of the Huesca-Jaca section of the line that was to link Zaragoza to the French border via Canfranc. Although this section was opened and operated by Norte from the outset, the original concession was granted to the Sociedad Anónima Aragonesa, which then ceded it to Norte.

As far as the reproduction is concerned, it should be noted that this is a kit of medium difficulty, in which you will find different types of materials, although basically high quality cardboard of various thicknesses. There are also some parts printed in 3D technology on PLA and aluminium tubes.

This guide is divided into the following sections

- Introduction (this section)
- Component parts
- Assembly instructions
- Drawings

We recommend that you read this manual in its entirety before proceeding with assembly.

If you have any doubts or questions, please contact us at admin@parvus.info and we will be happy to answer them.

Finally, we encourage you to send us photos of the result; they will become part of our library of assembled references if you allow us to publish them on social networks, and will undoubtedly serve to inspire future enthusiasts.

Parvus, November 2024

H0111 Estación de Sabiñanigo **Despiece** (tamaño al 50%)

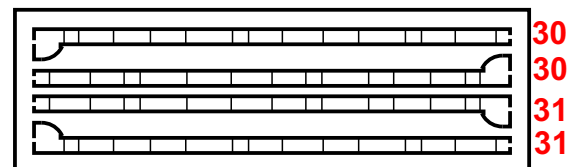
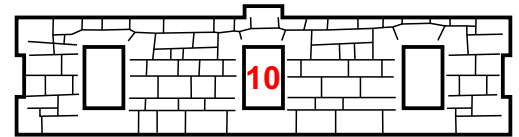
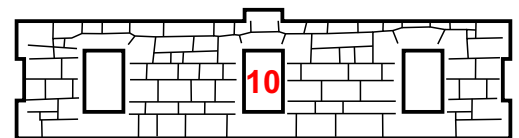
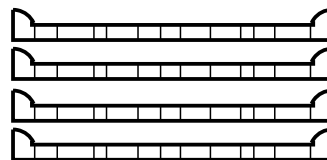
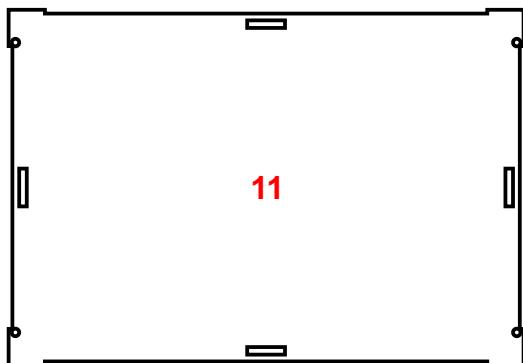
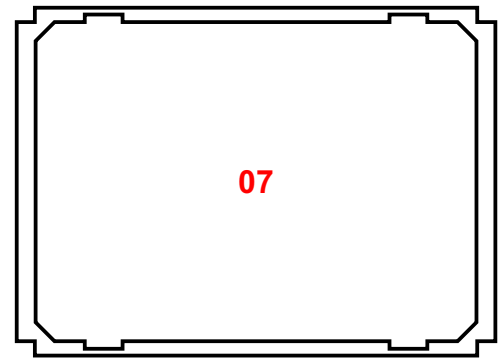
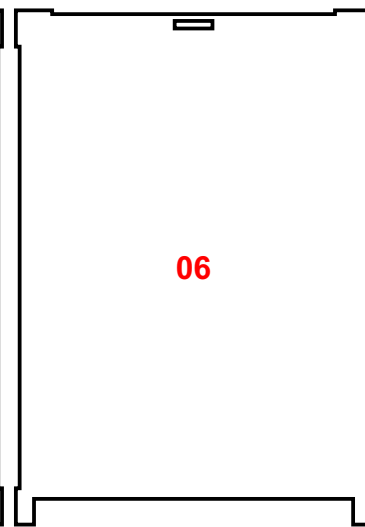
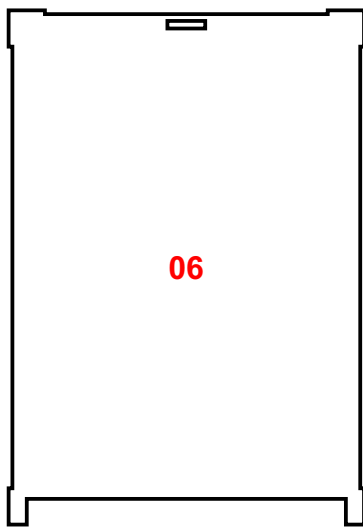
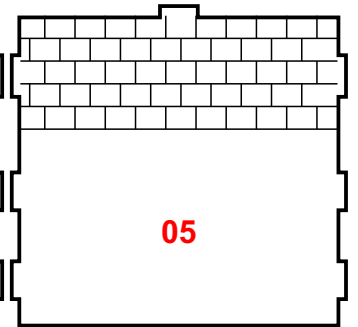
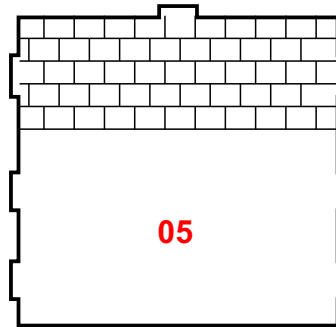
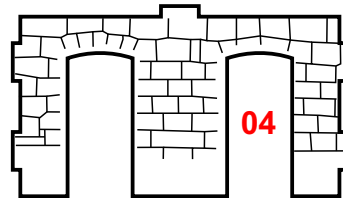
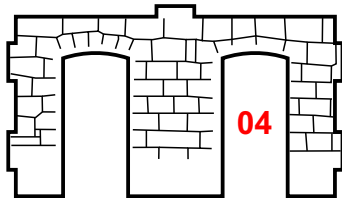
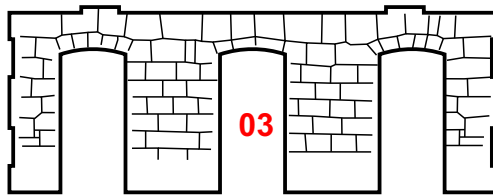
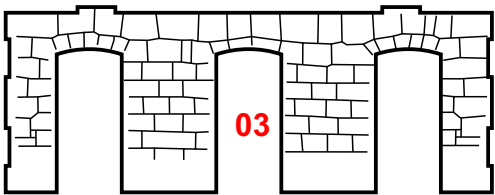
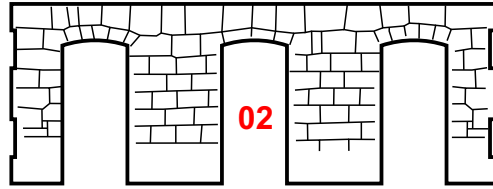
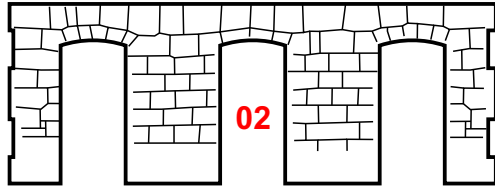
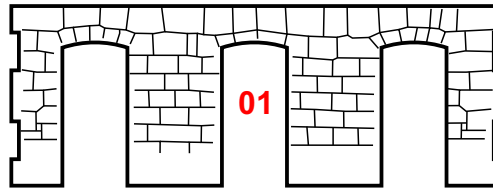
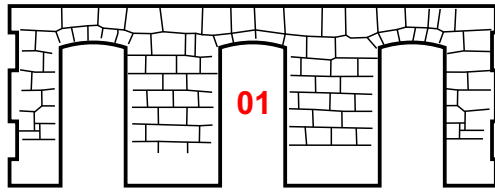

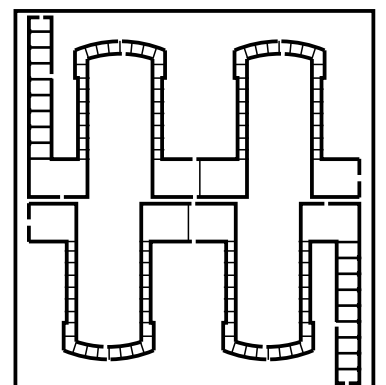
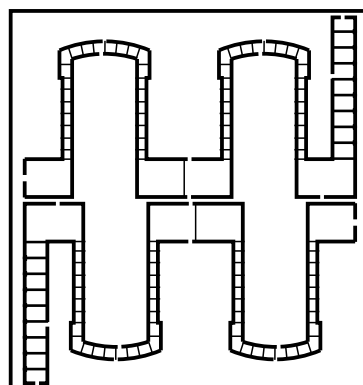
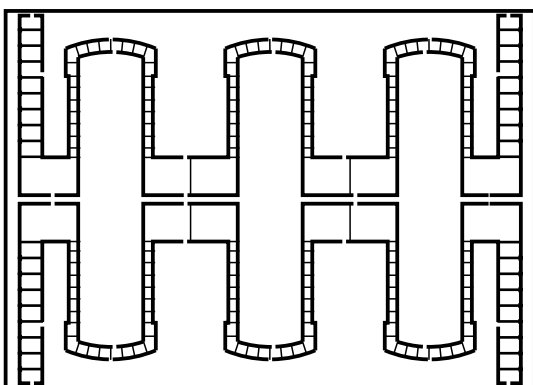
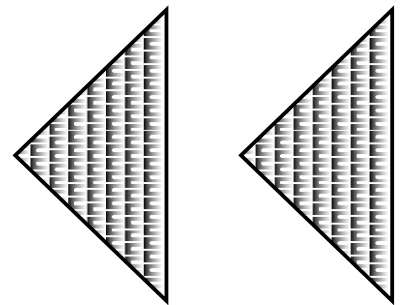
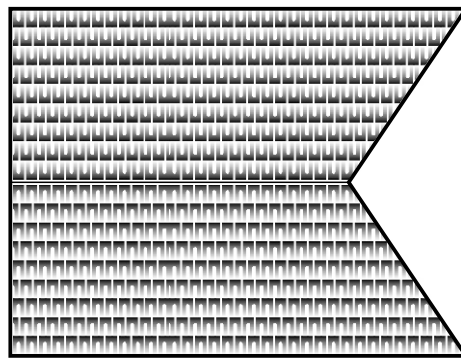
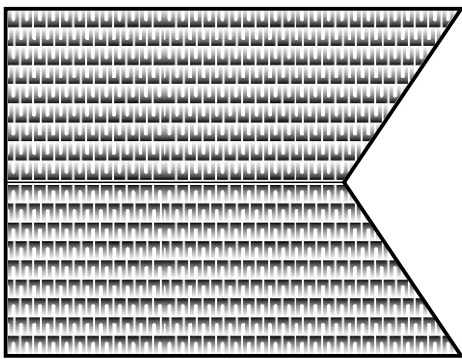
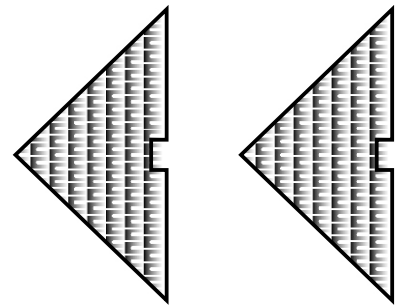
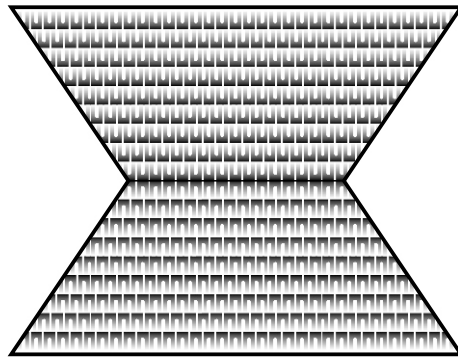
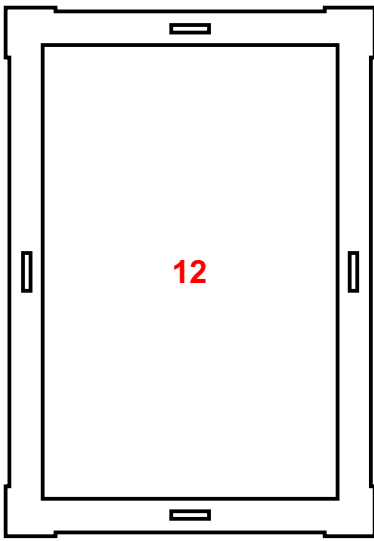
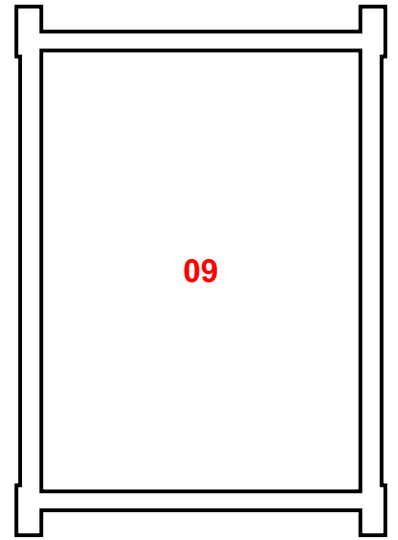
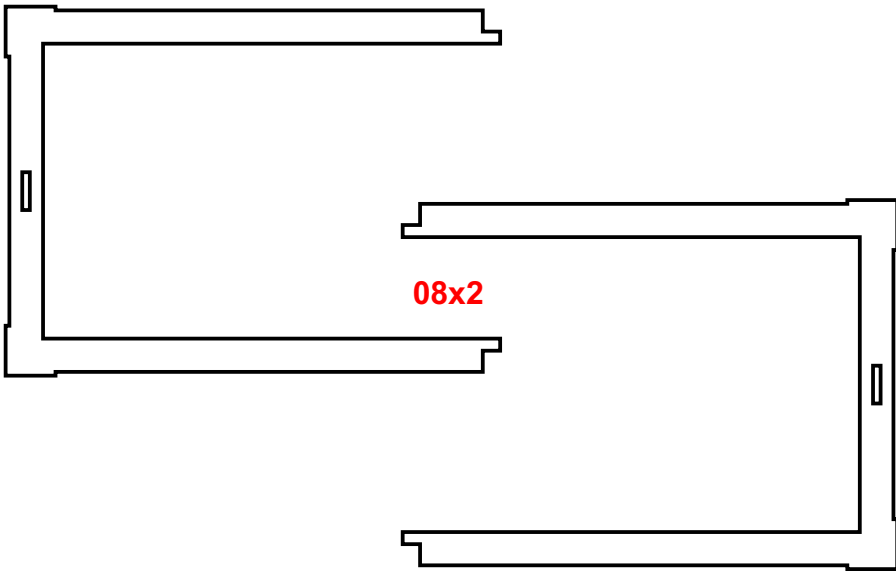

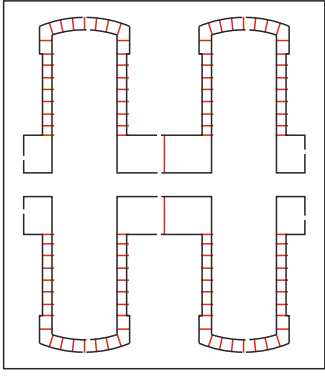

16 x 2

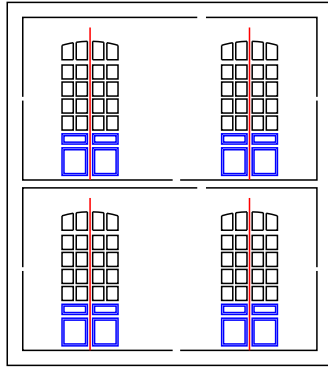

23 x 2

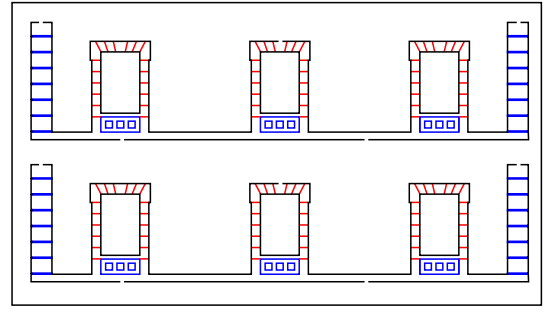

18 x 2

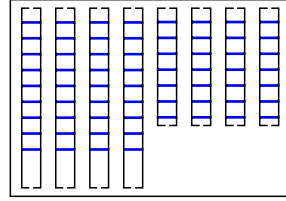

17 x 4

19 x 4

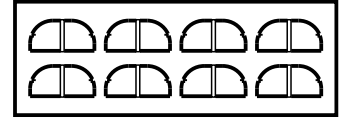

32 x 8

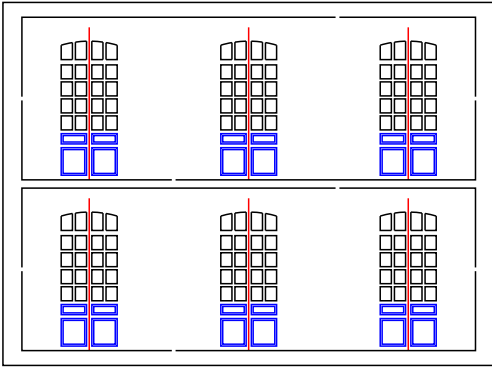

22 x 2

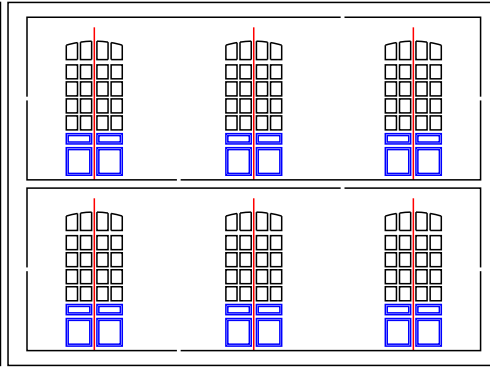

22 x 2

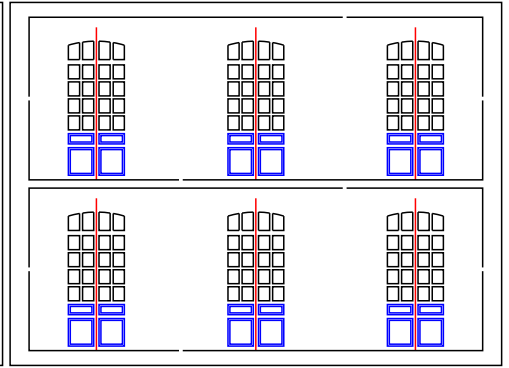

22 x 2

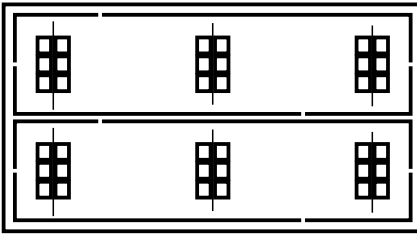

24 x 2

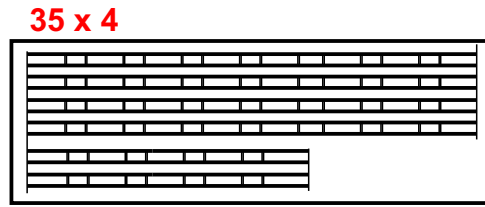

35 x 4

36 x 2

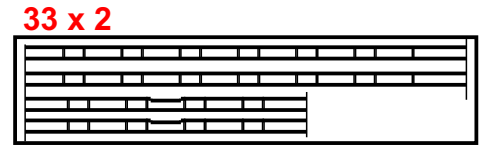

33 x 2

34 x 2



25 x 2



25 x 2



25 x 2



26 x 2



27 x 2



39

20 x 8

21 x 4

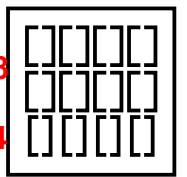

37 x 4



38 x 4

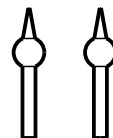

40 x 2

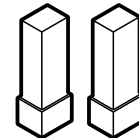

41 x 2

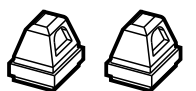

42 x 2

H0111 Sabiñánigo - manual montaje

Este manual está editado en base al montaje de la estación de Ayerbe, allí donde difieran las piezas, estará indicado en un texto como este.

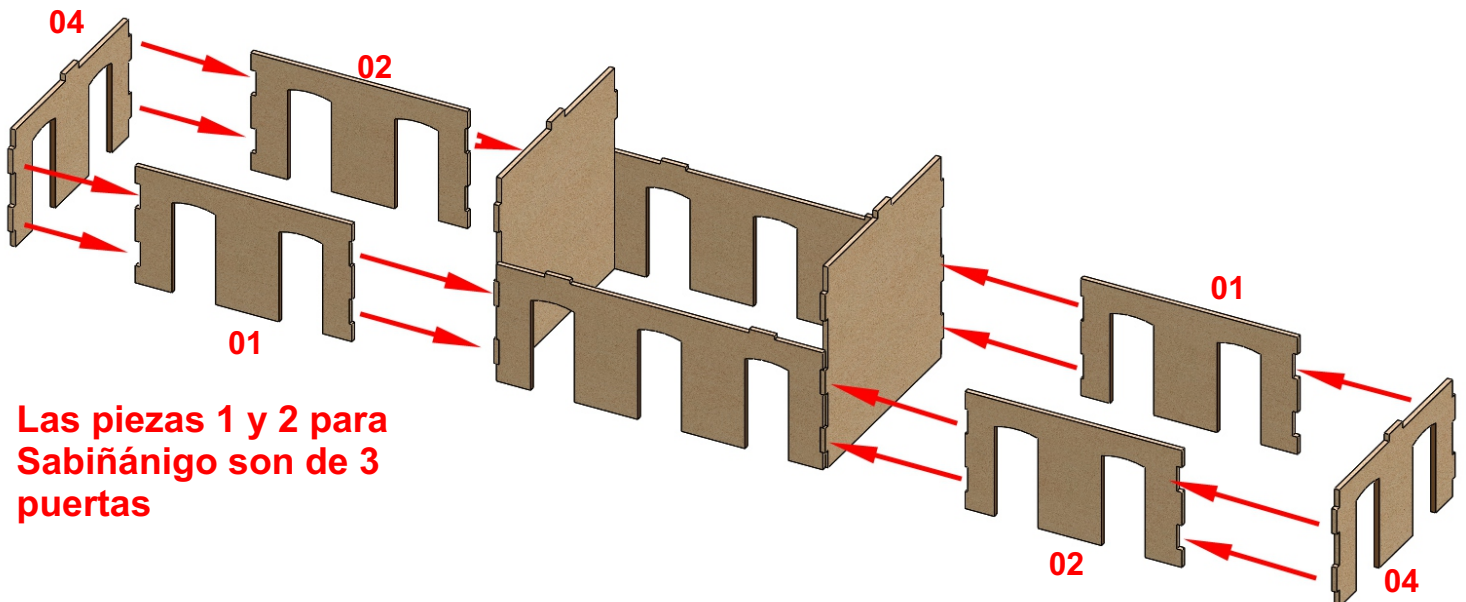
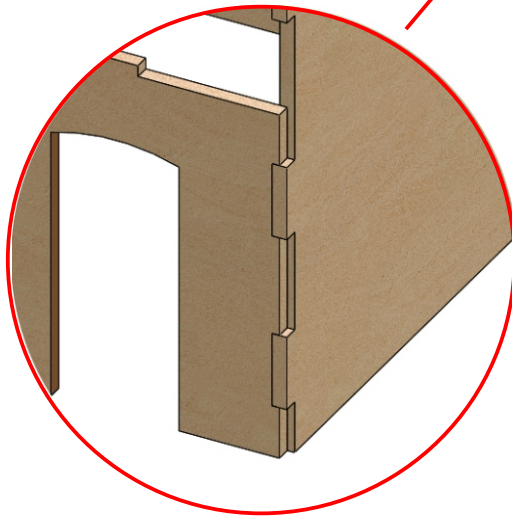
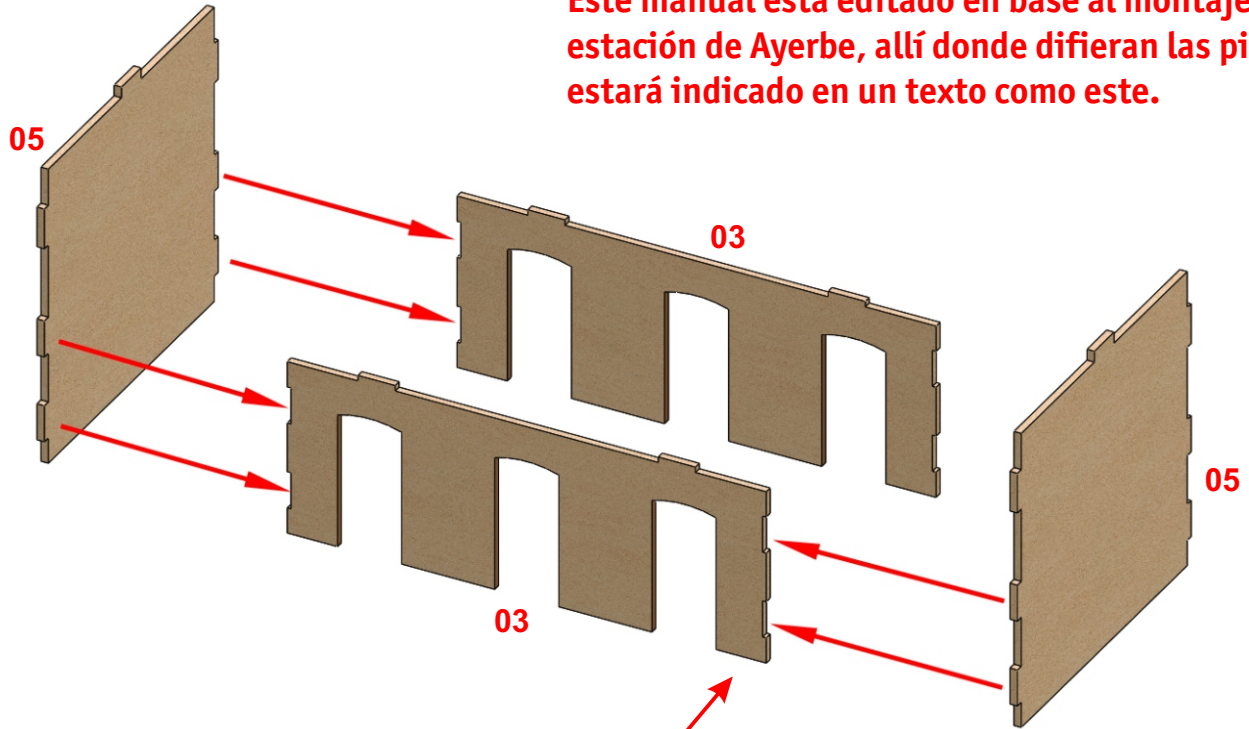

Las piezas 1 y 2 para Sabiñánigo son de 3 puertas

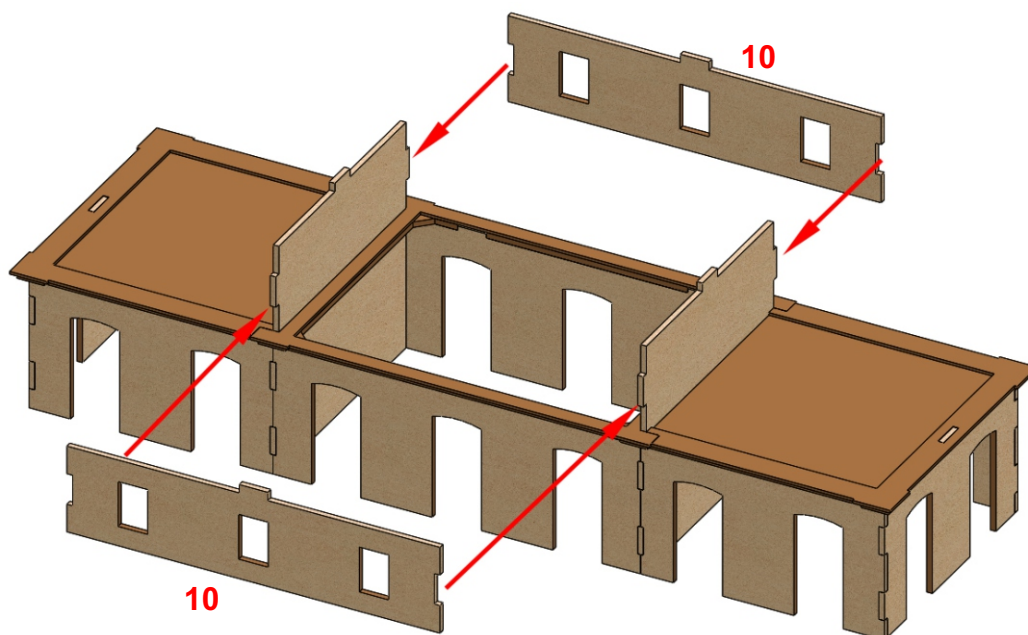
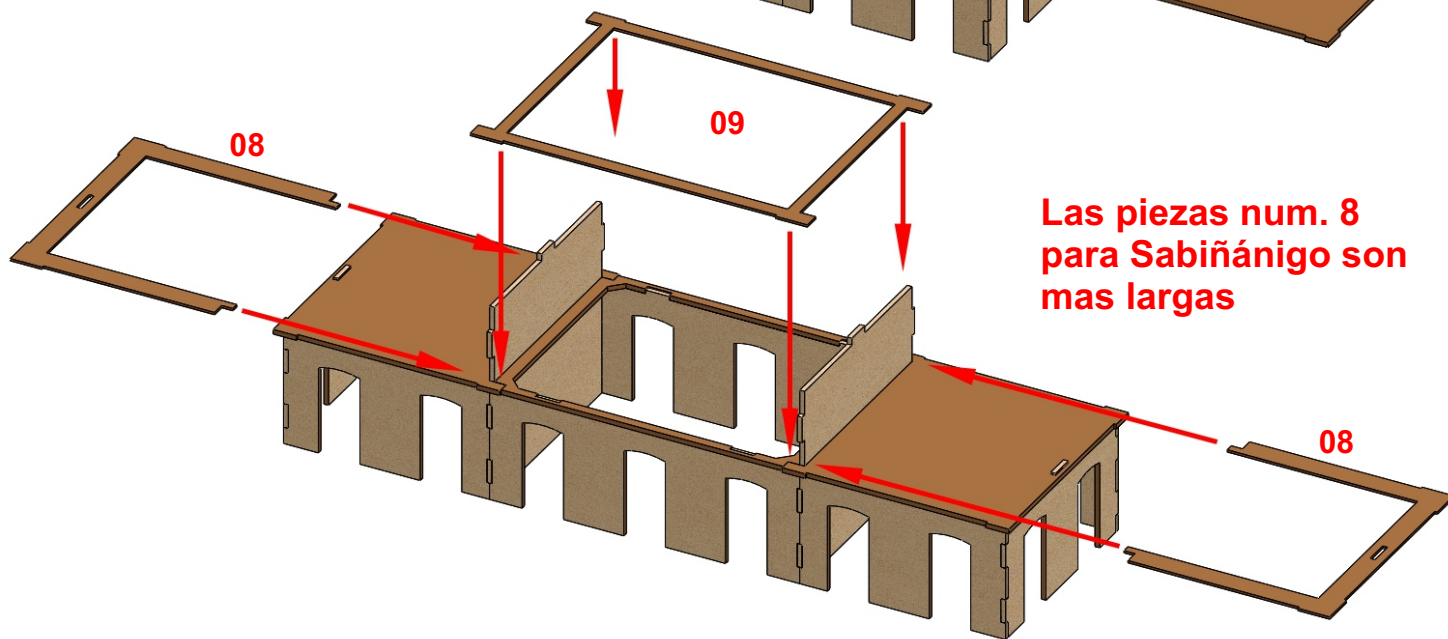
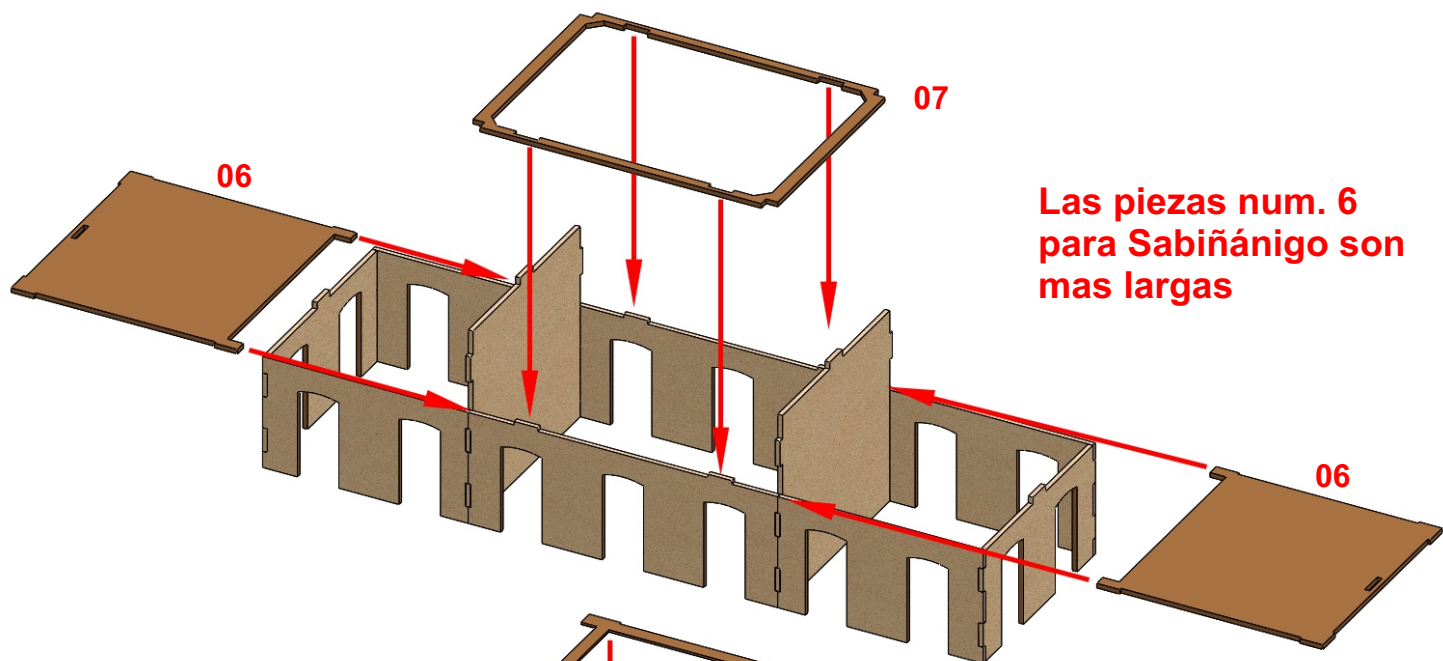

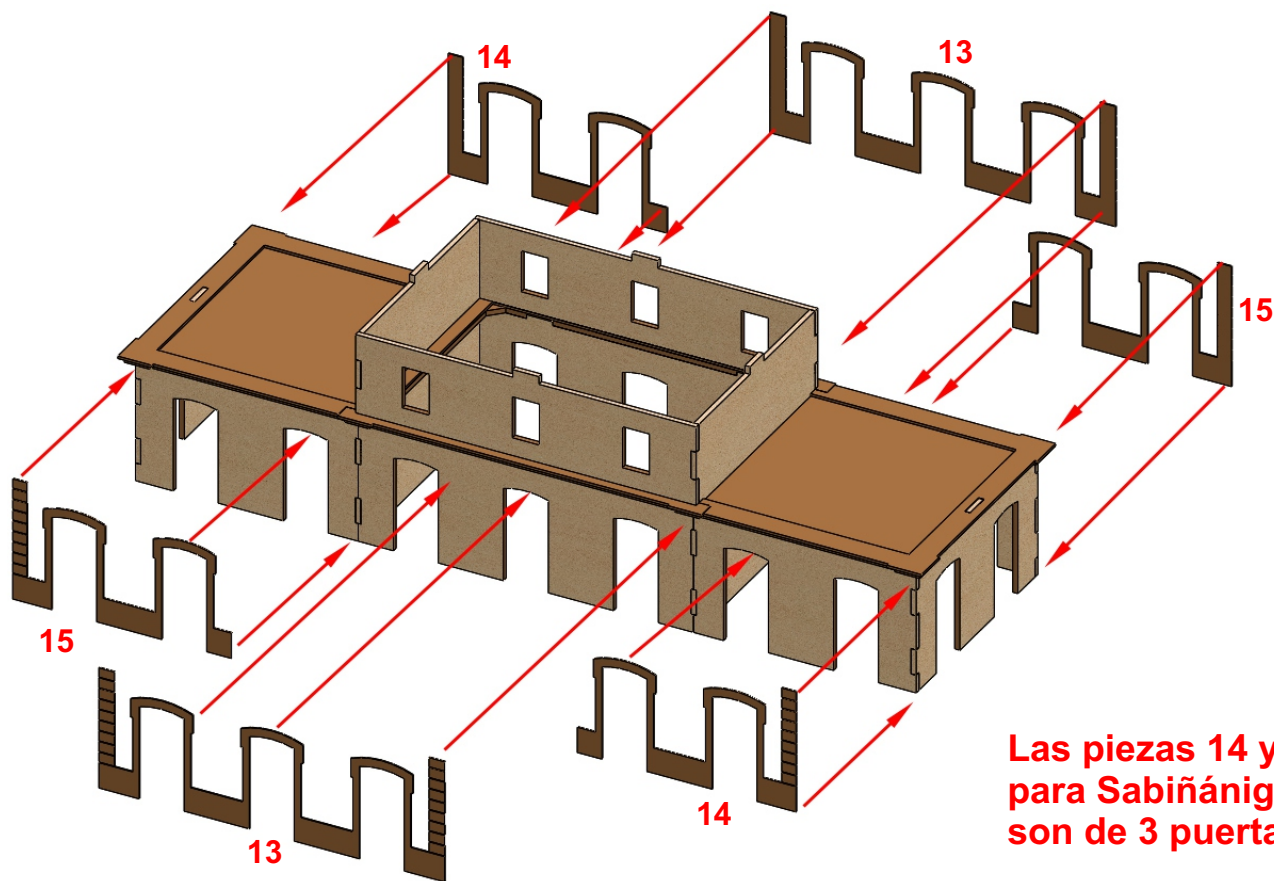

Las piezas 14 y 15 para Sabiñánigo son de 3 puertas

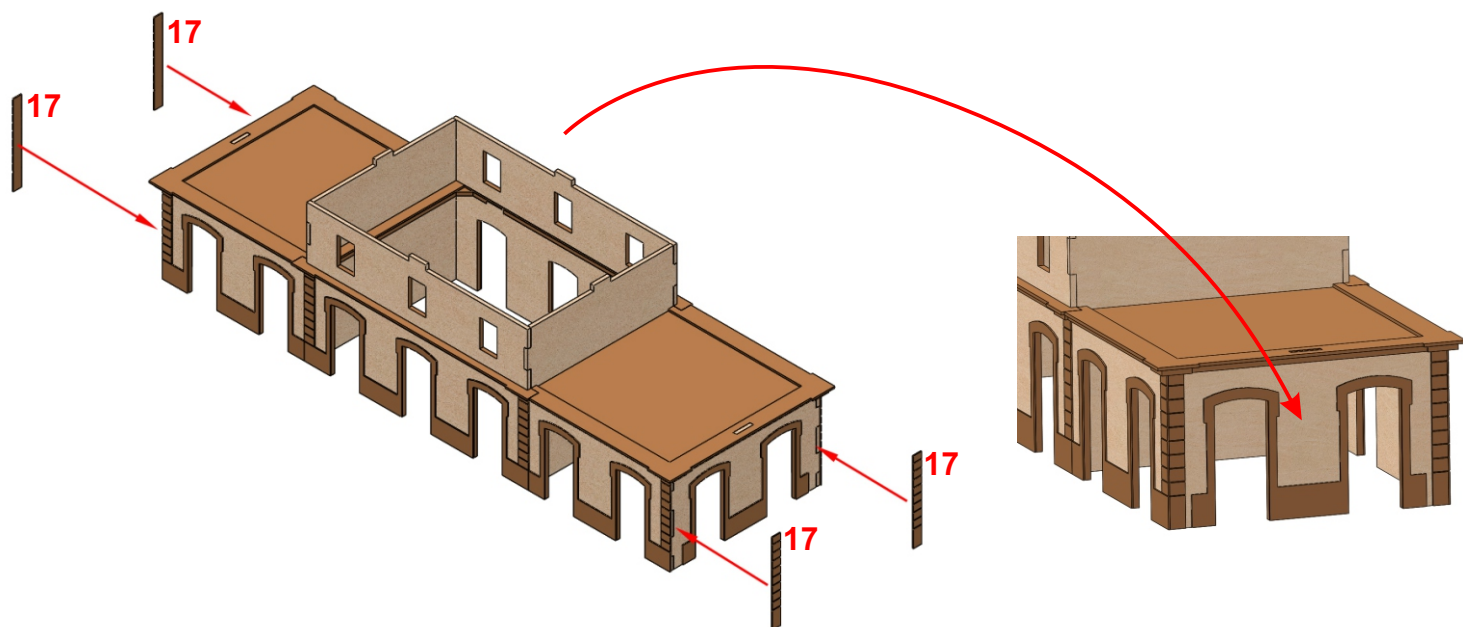
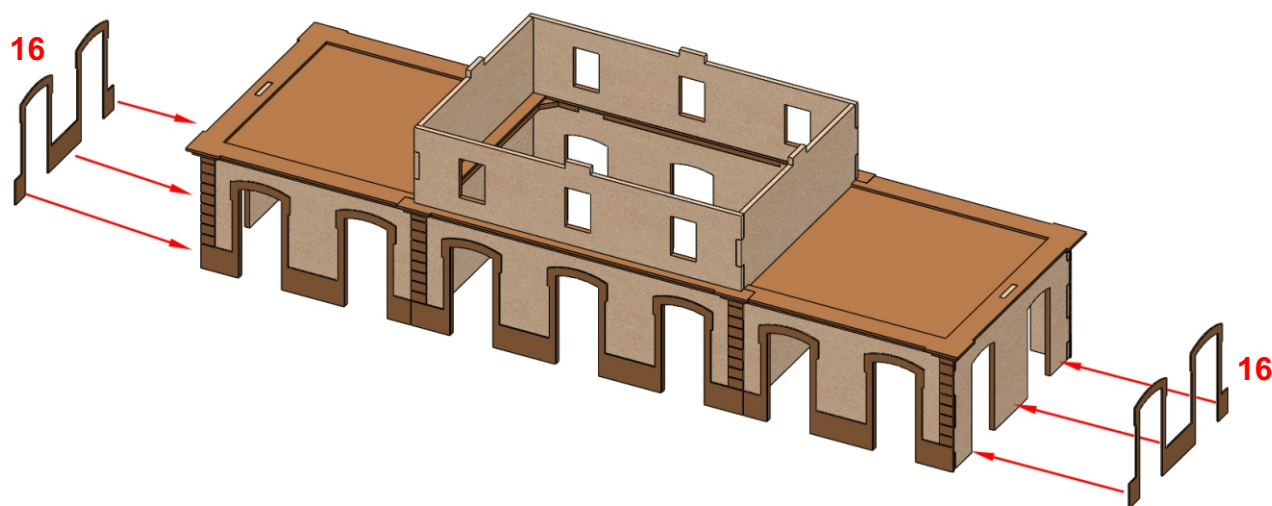

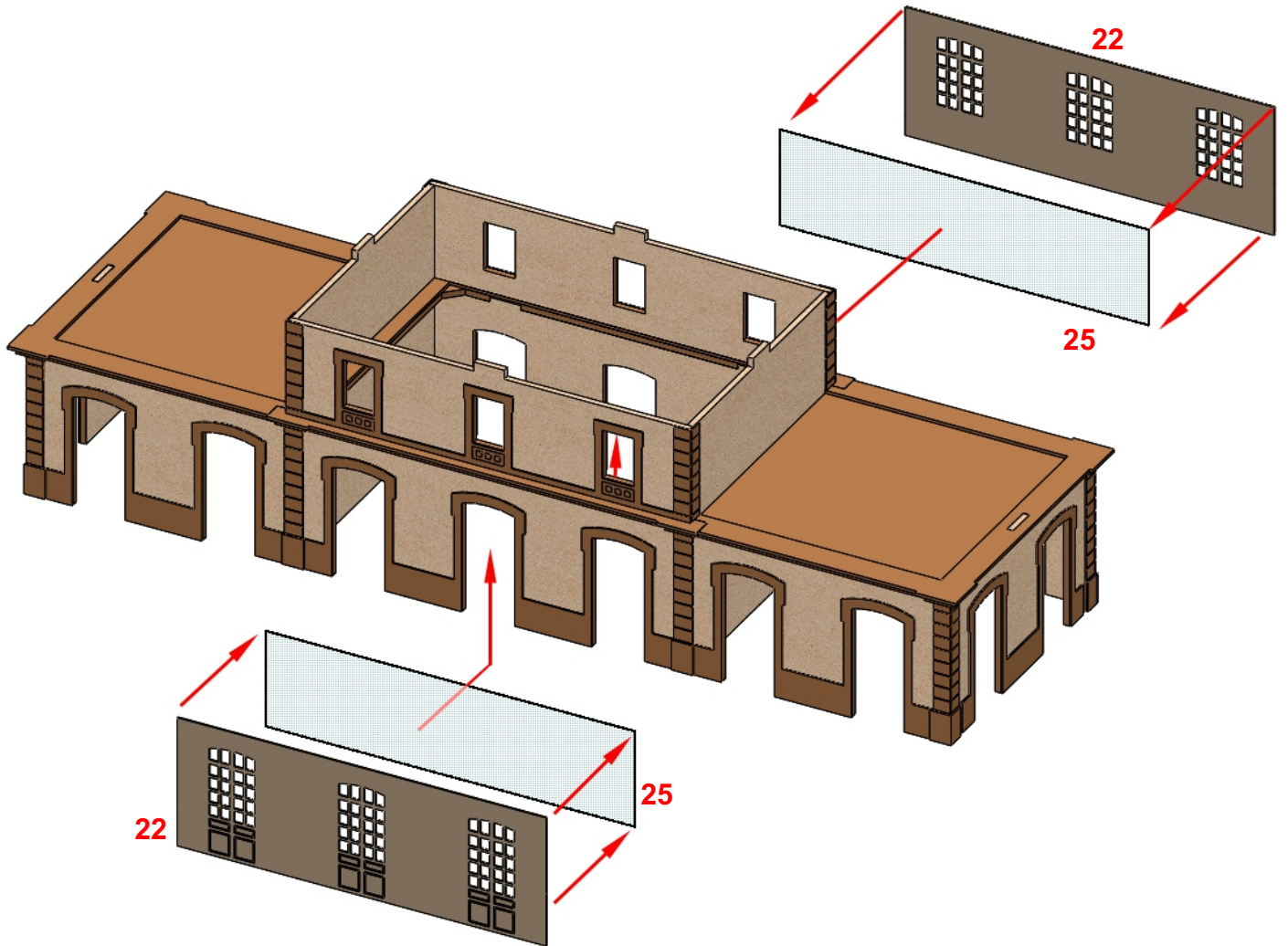
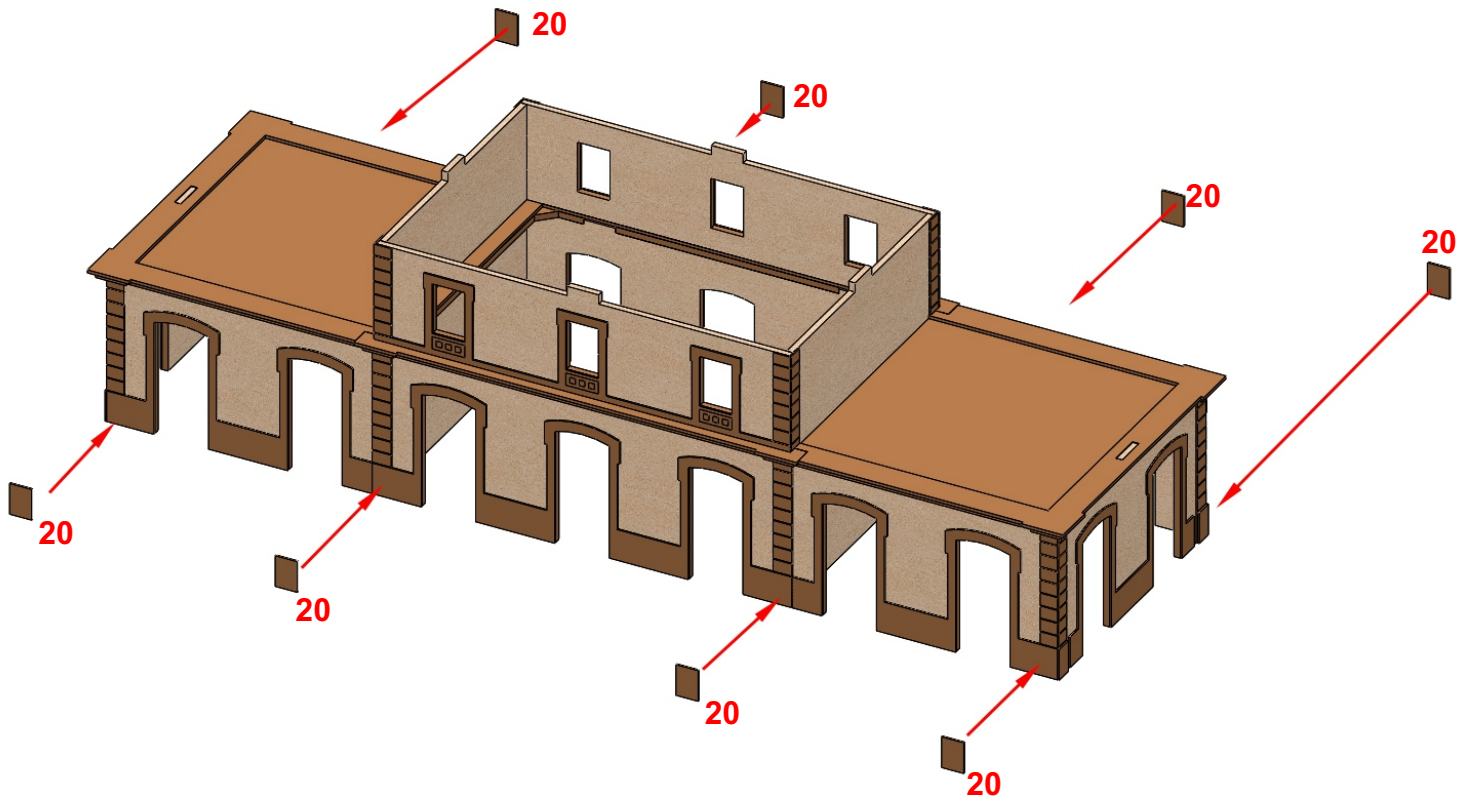

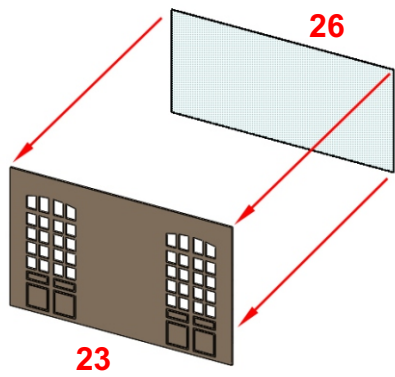

Para Sabiñánigo la carpintería y los cristales son 2 unidades de dos puertas y 6 unidades de 3 puertas

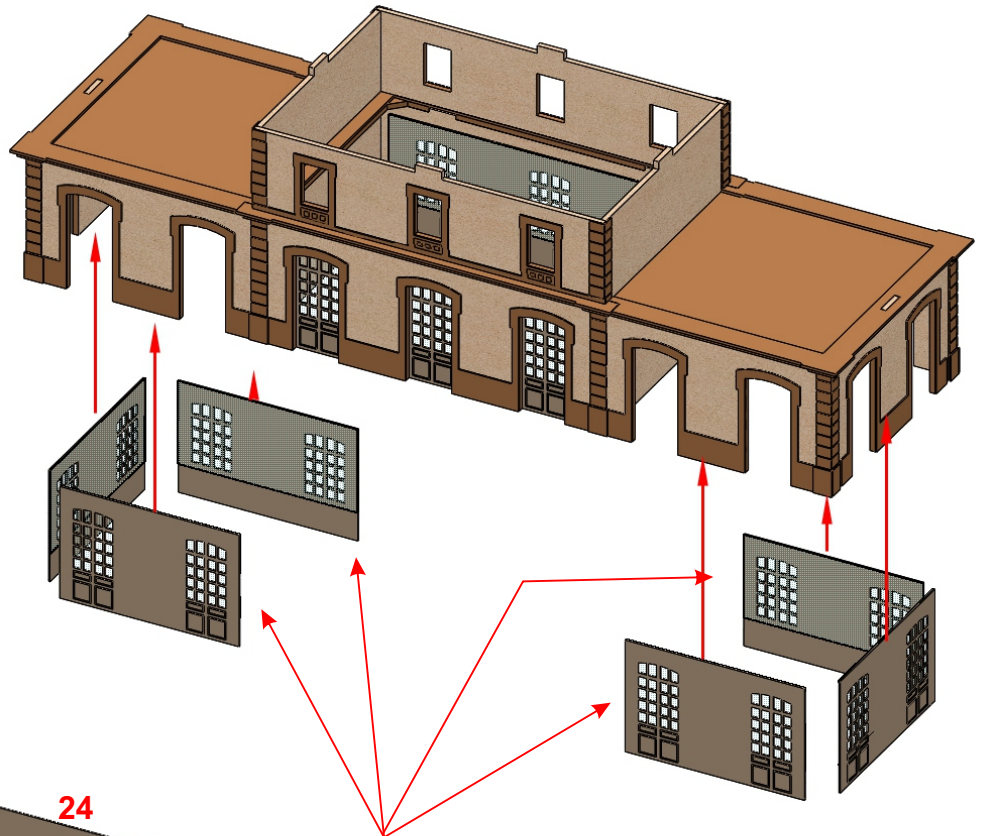

Estas 4 piezas son de 3 puertas en Sabiñánigo

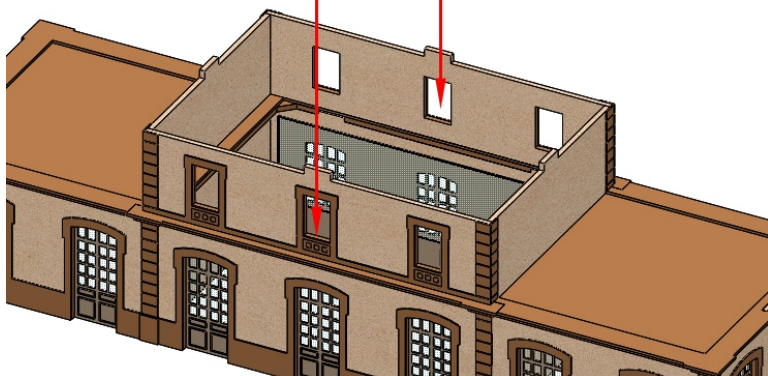
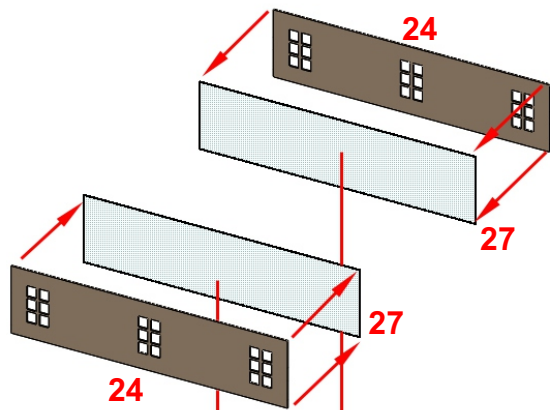

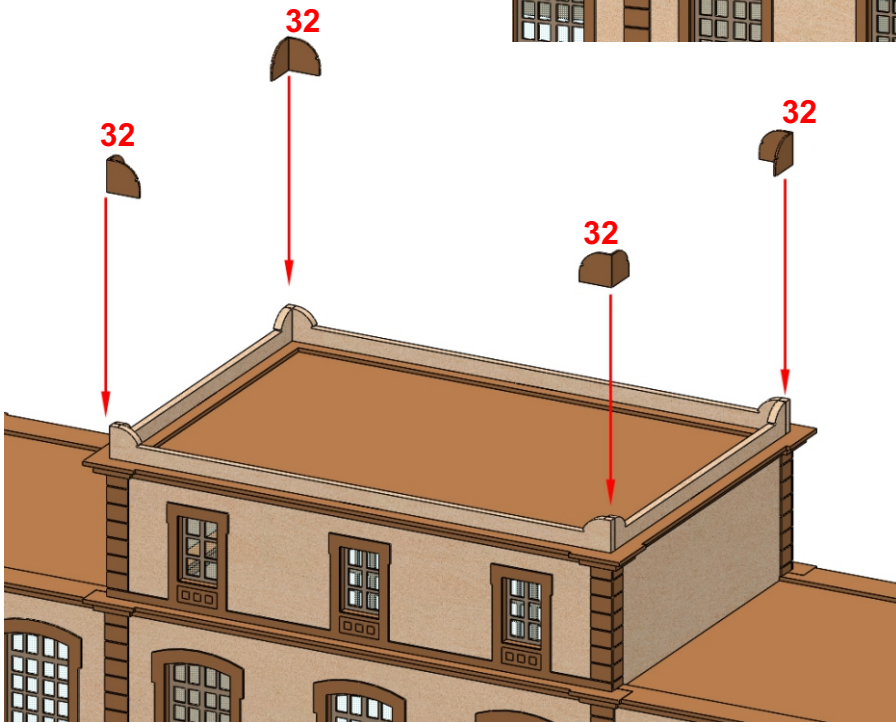
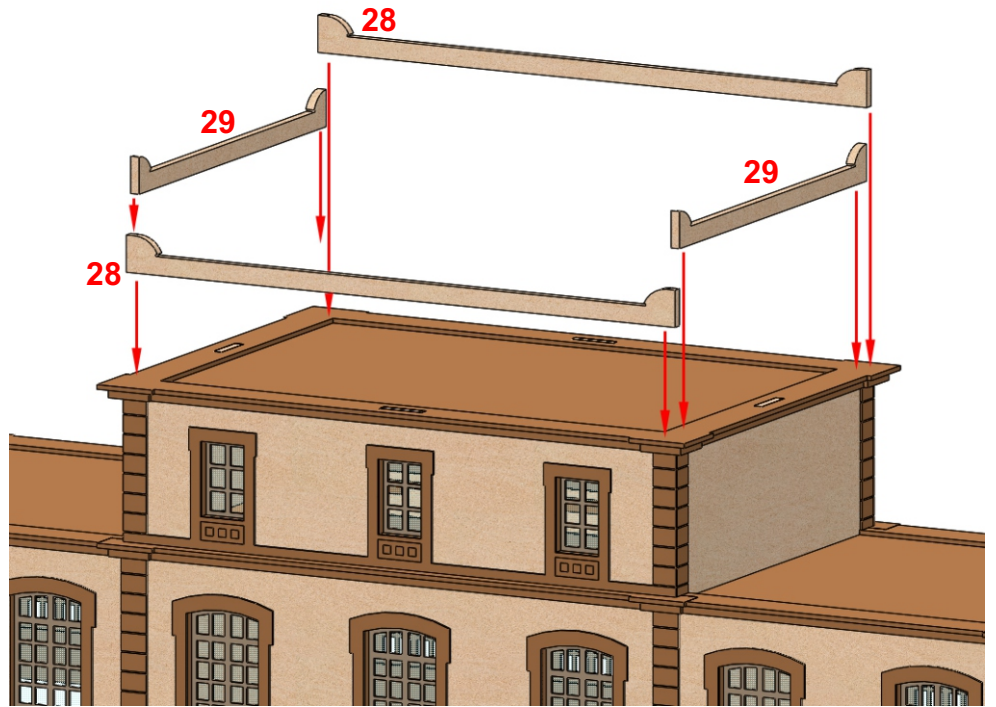
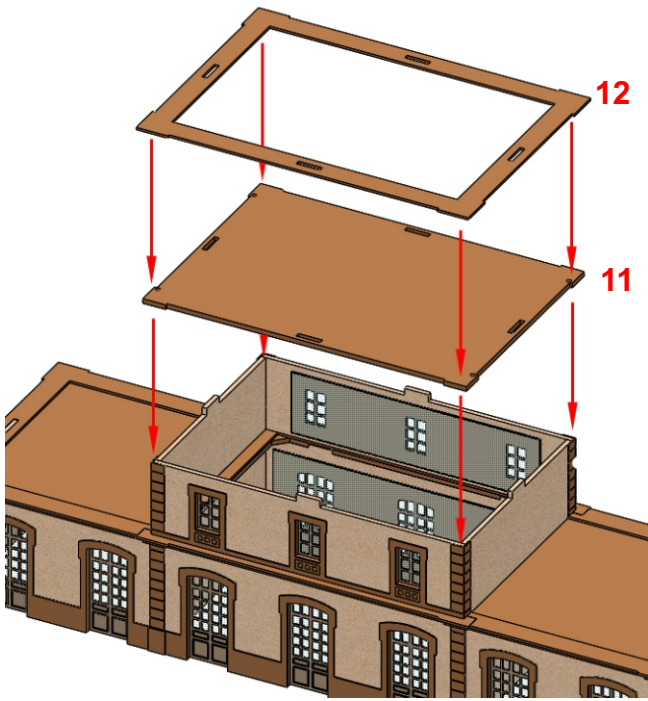

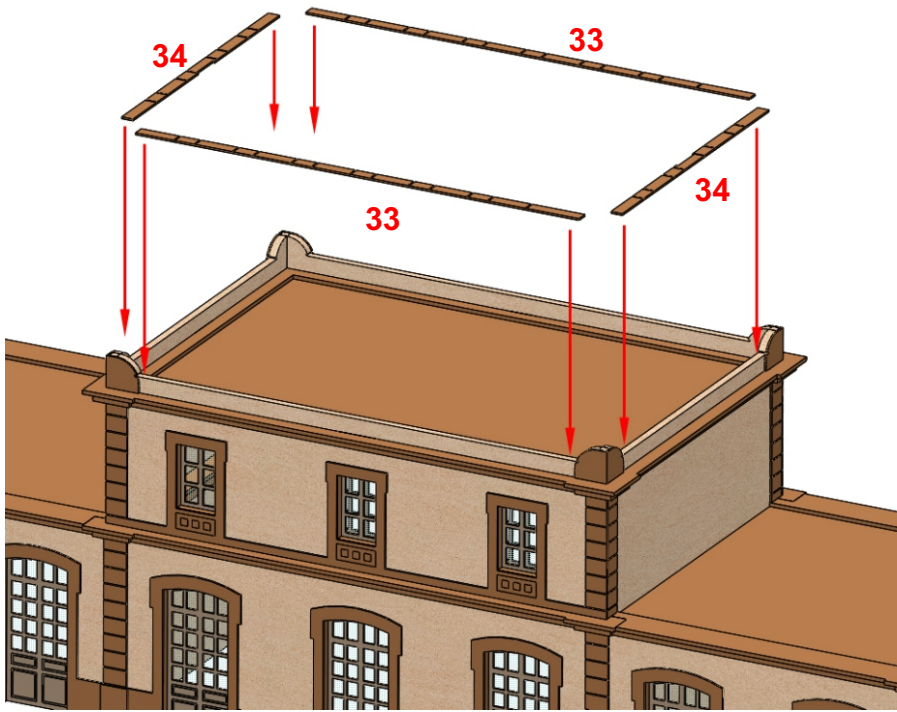

Las piezas 30 y 31 para Sabiánigo son mas largas

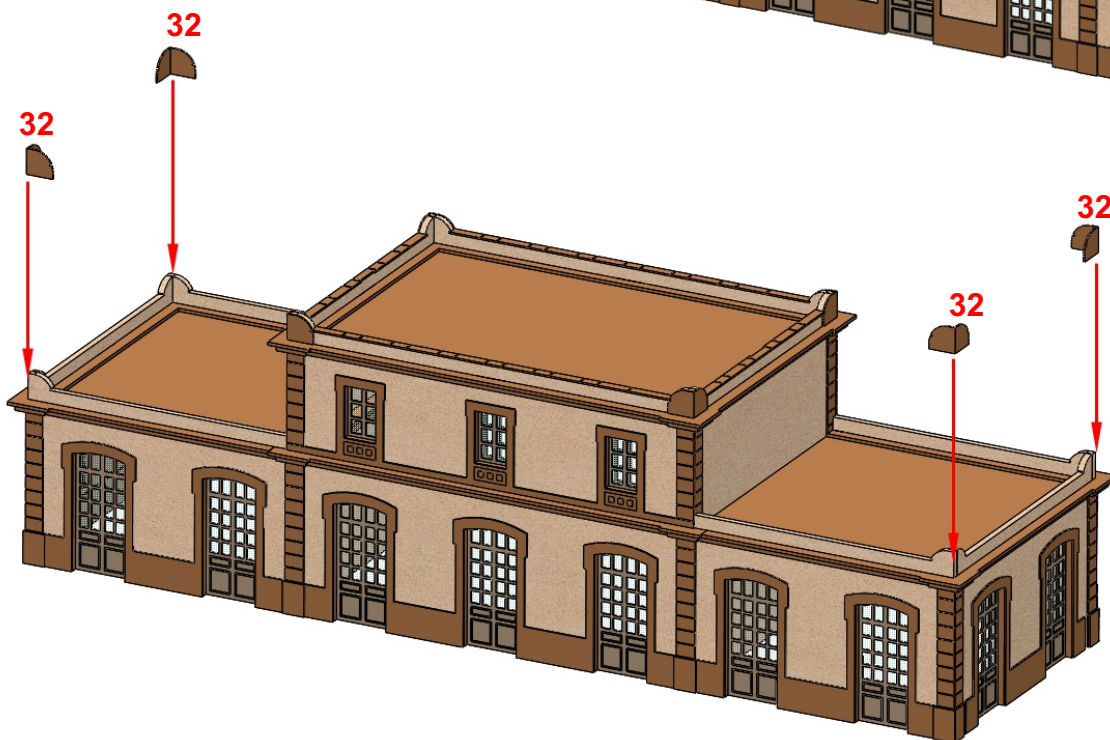
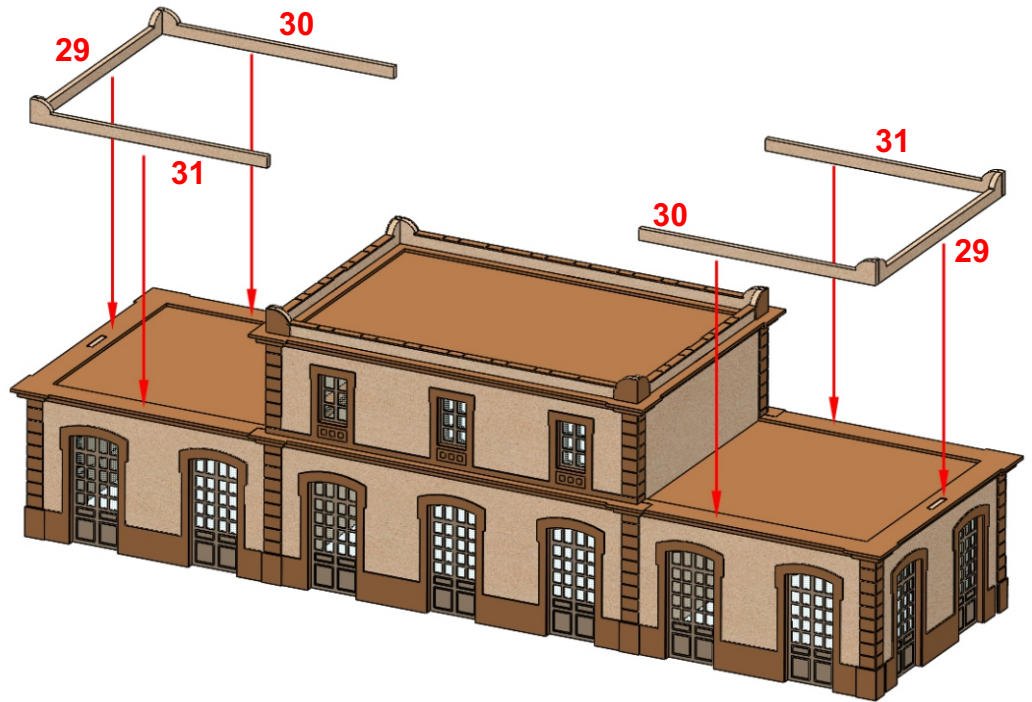

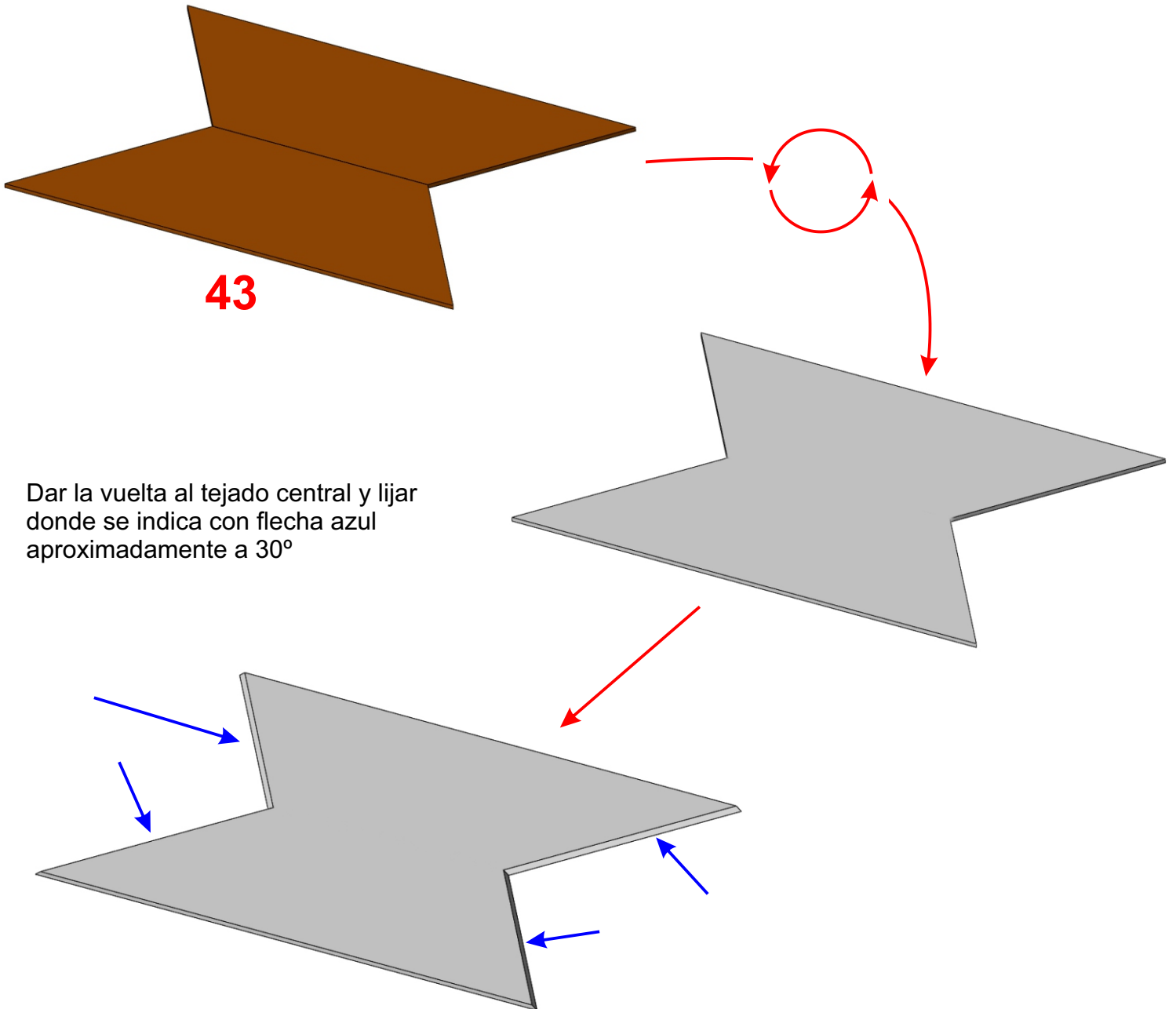
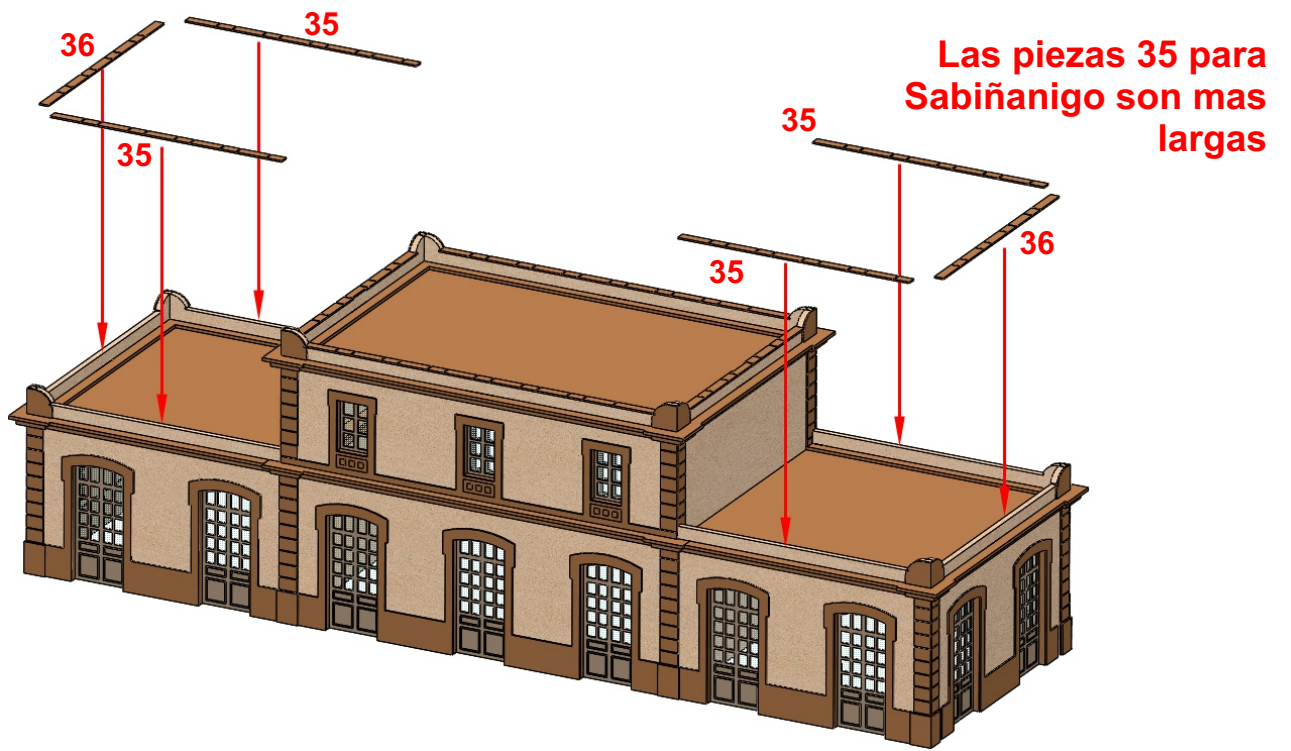

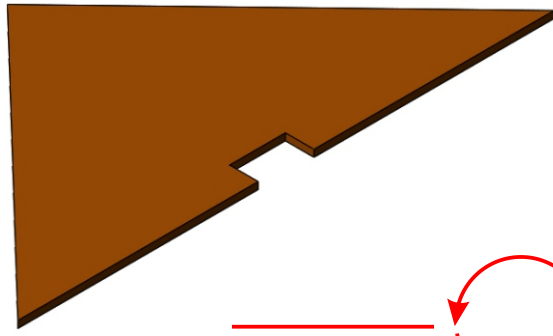

44

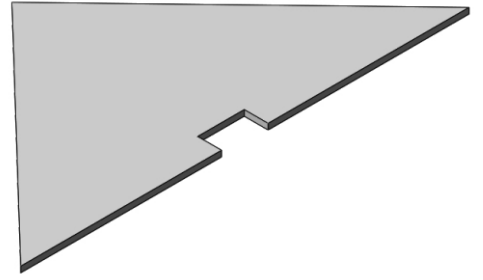
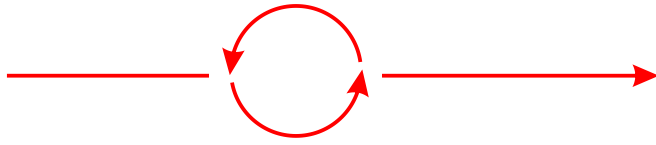

Dar la vuelta a las piezas 44
y lijar donde se indica con
flecha azul
aproximadamente a 30°

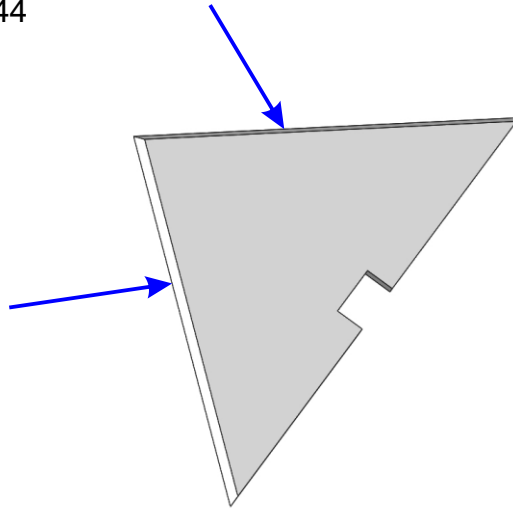

x 2

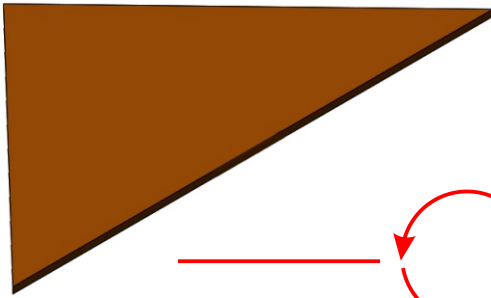

46

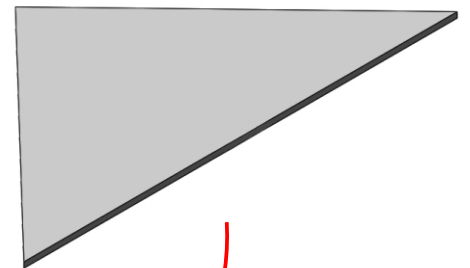
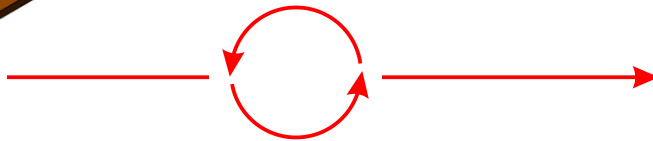

Dar la vuelta a las piezas 46
y lijar donde se indica con
flecha azul
aproximadamente a 30°

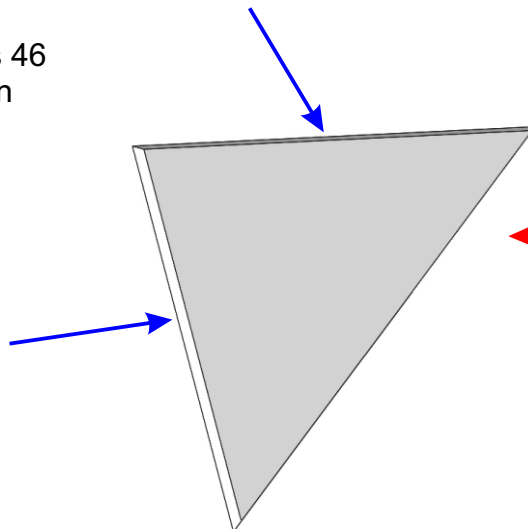

x 2

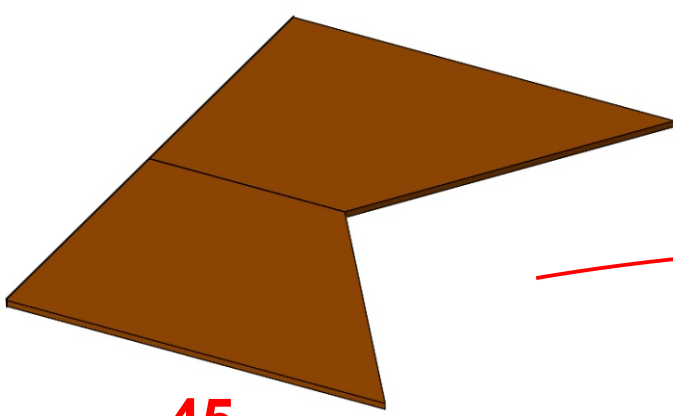

45

Dar la vuelta a las piezas 45
y lijar donde se indica con
flecha azul
aproximadamente a 30°

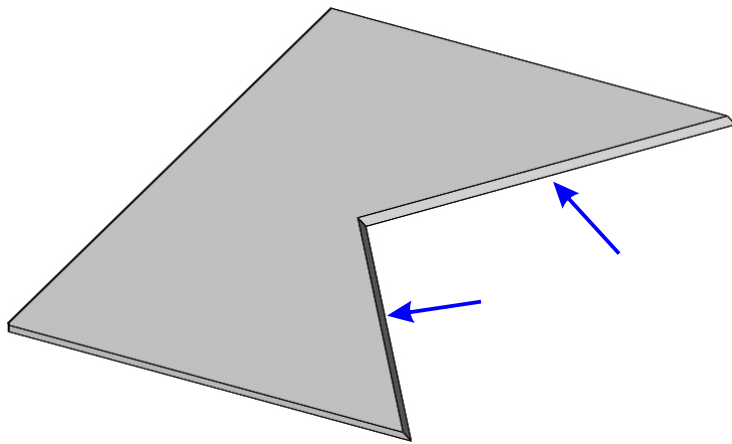
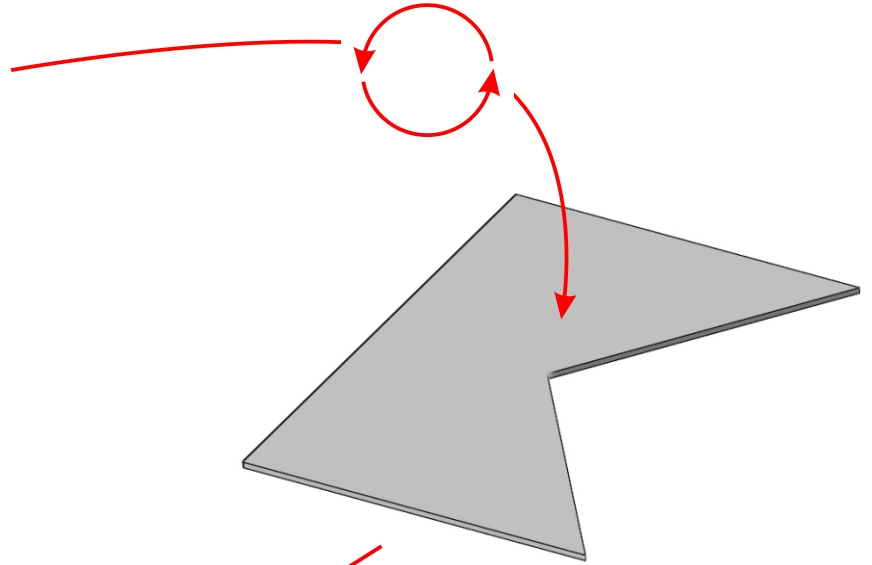

x 2

Las piezas 45 para
Sabiñánigo son mas
largas

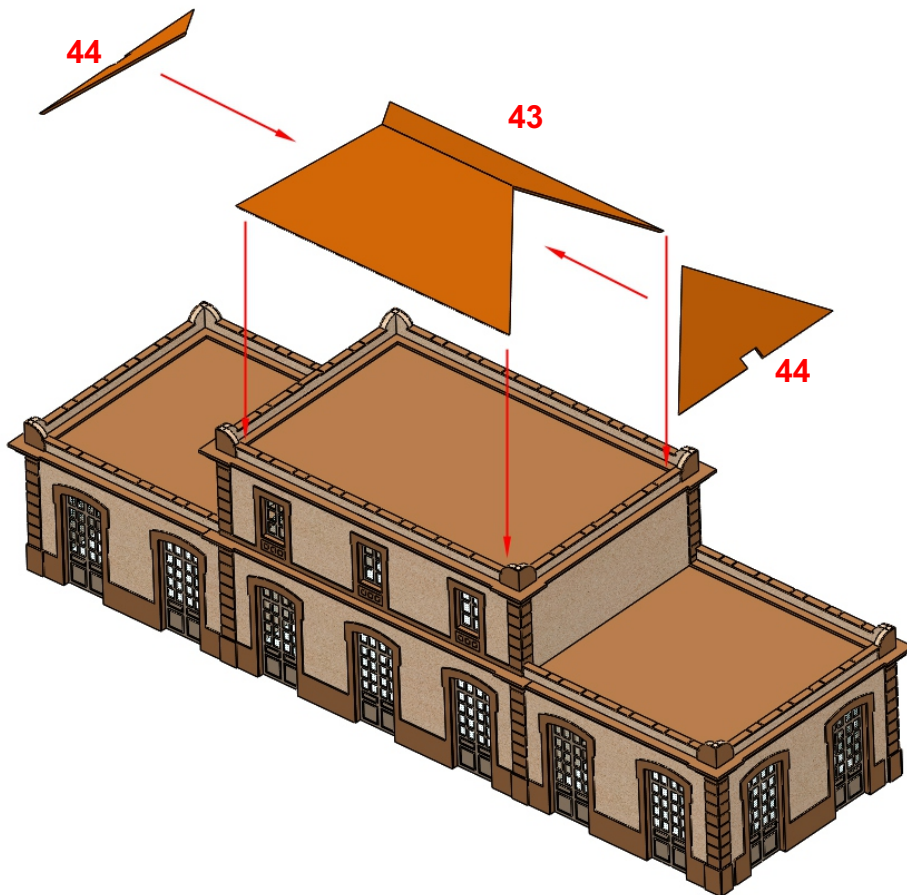

Las piezas 45 para Sabiñánigo son mas largas

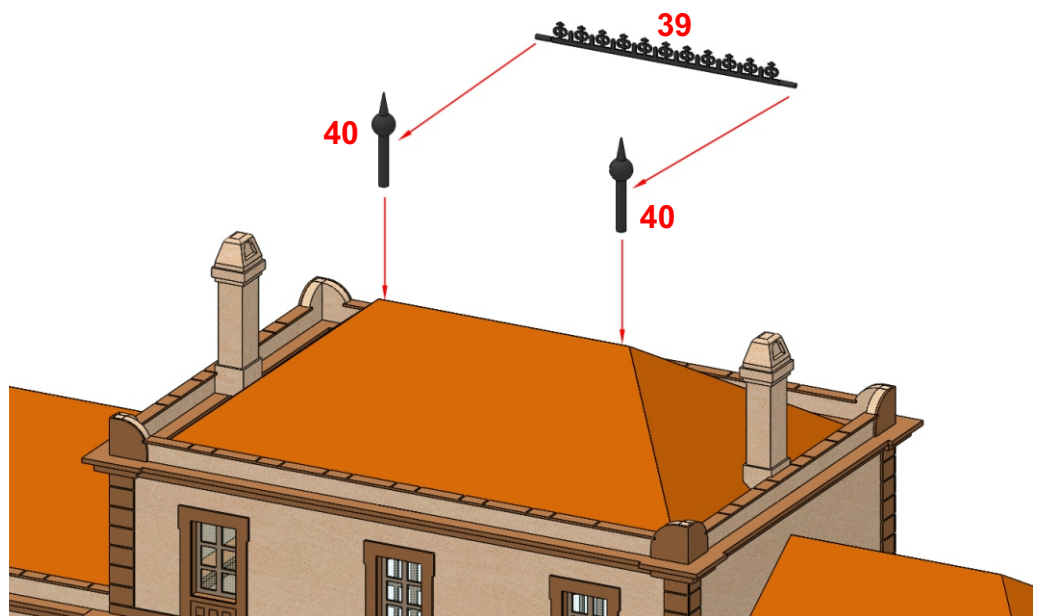
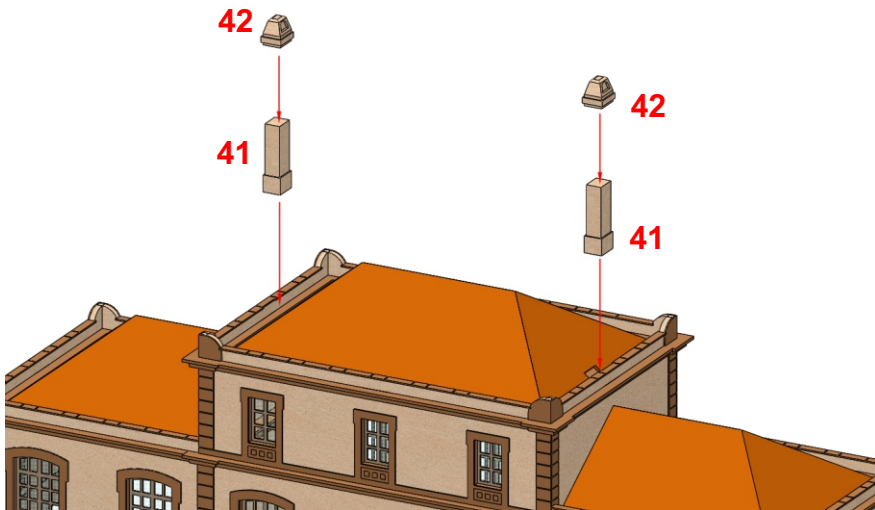
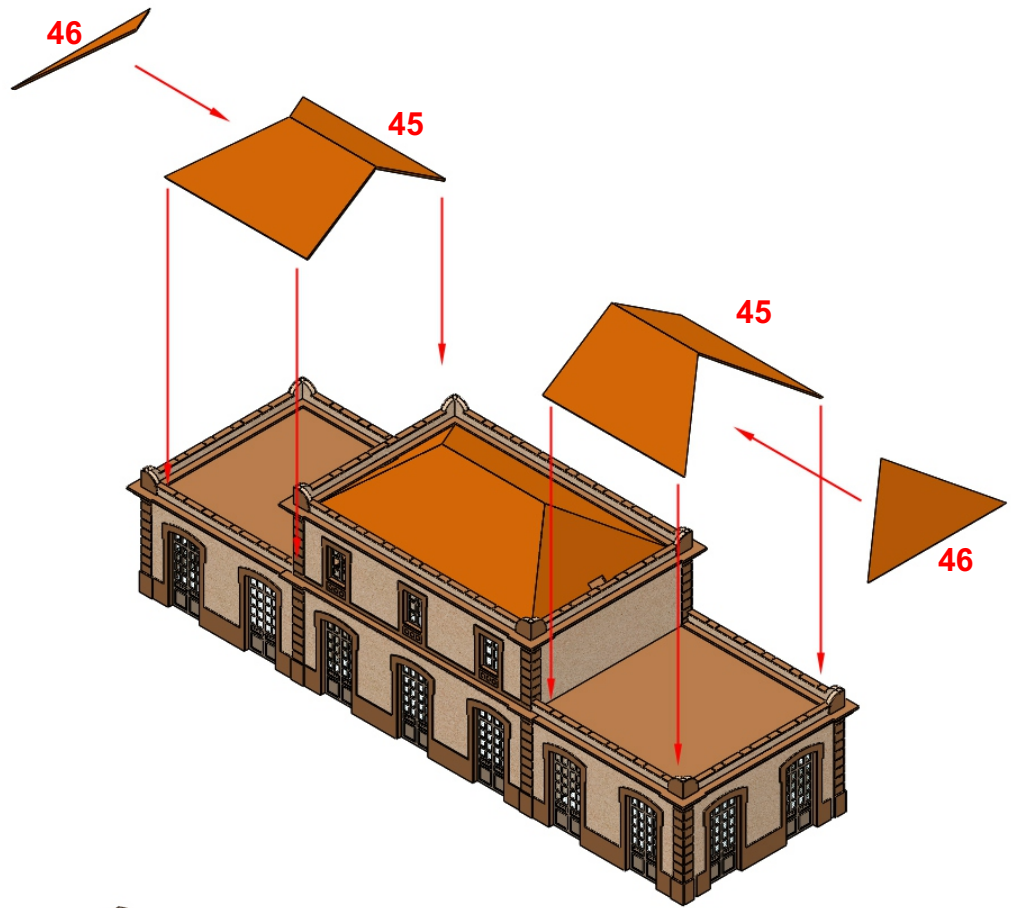

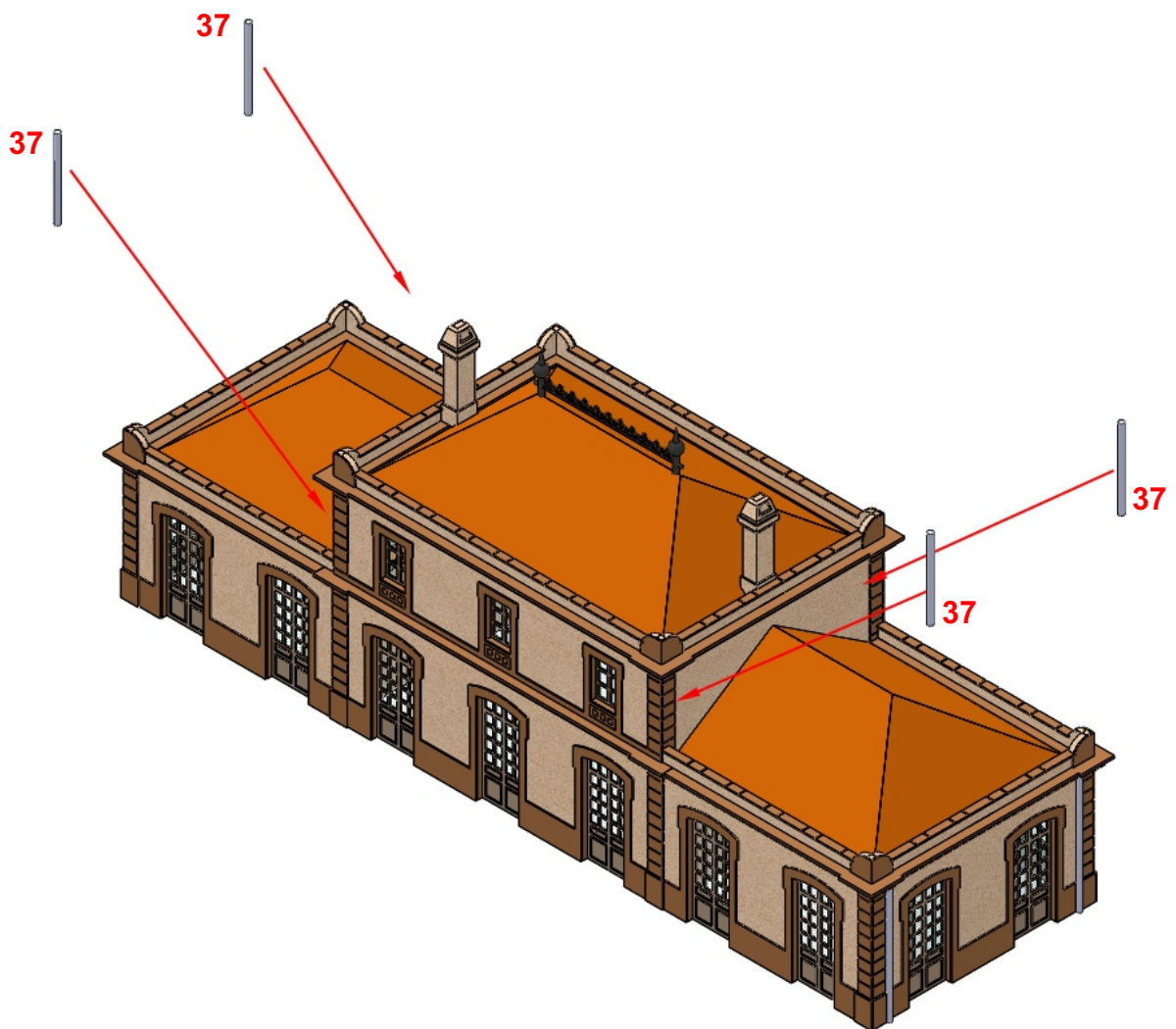
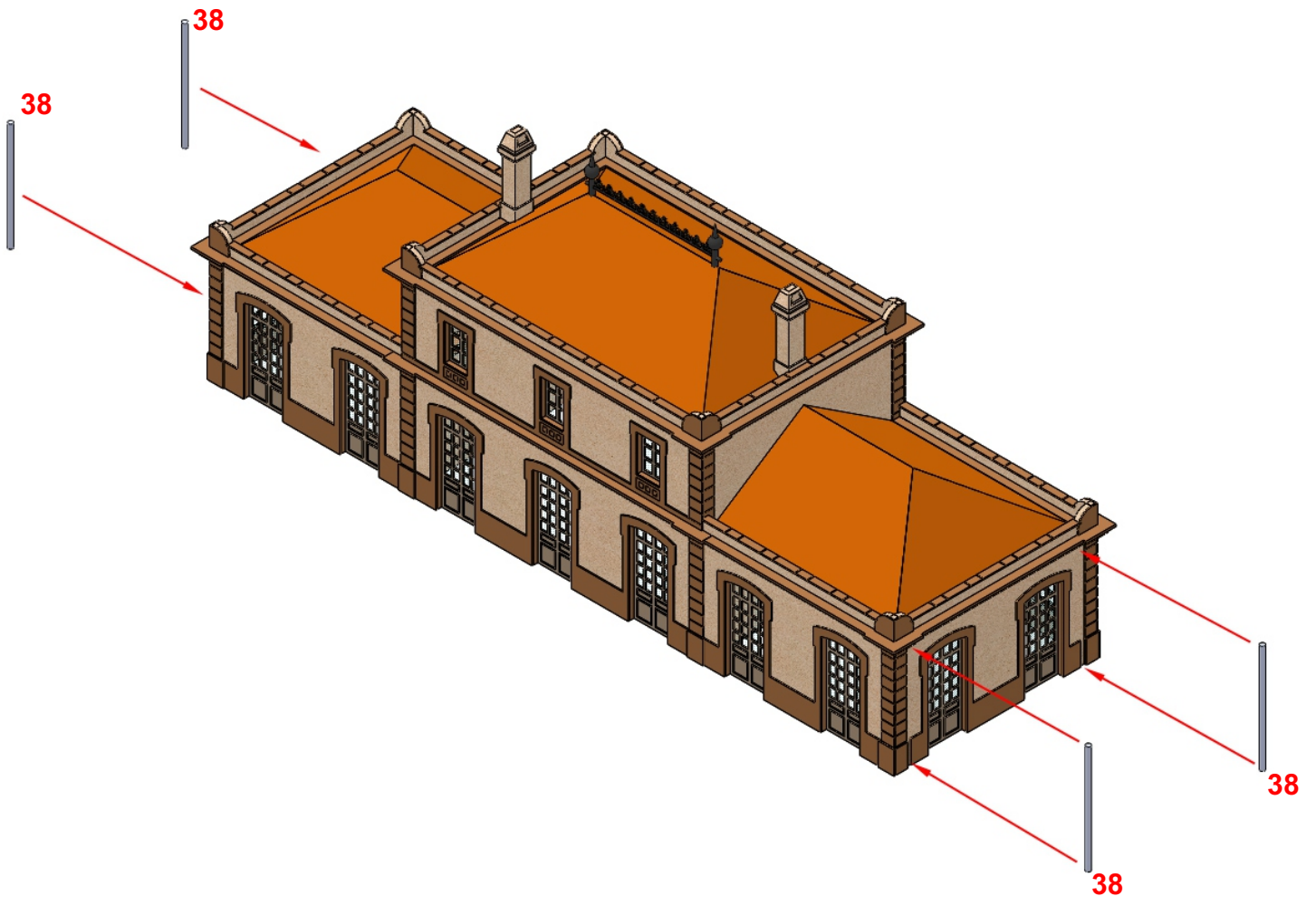

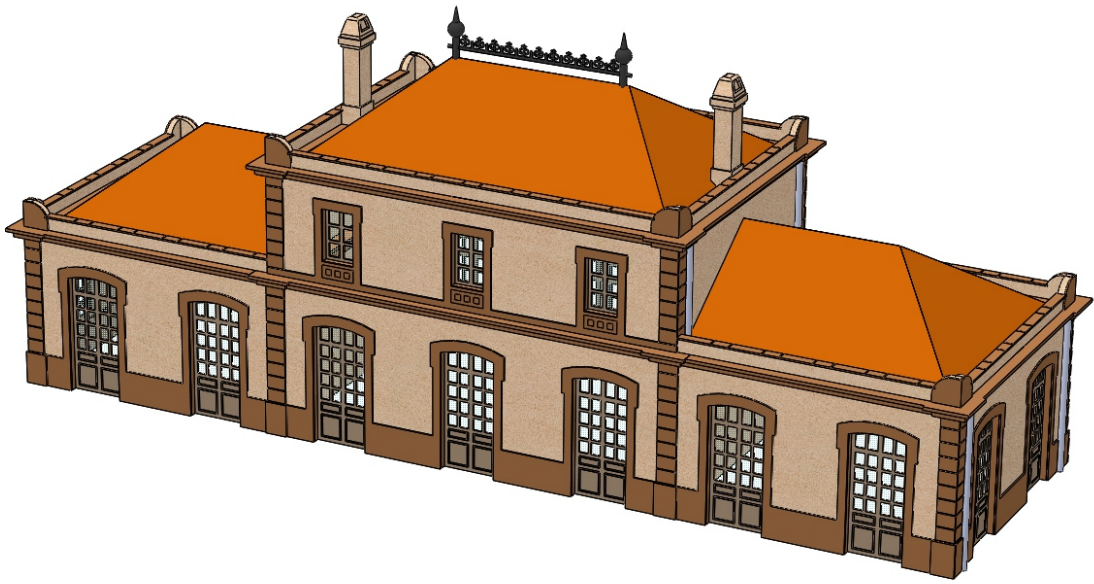

Estación de Ayerbe y Jaca en escala H0

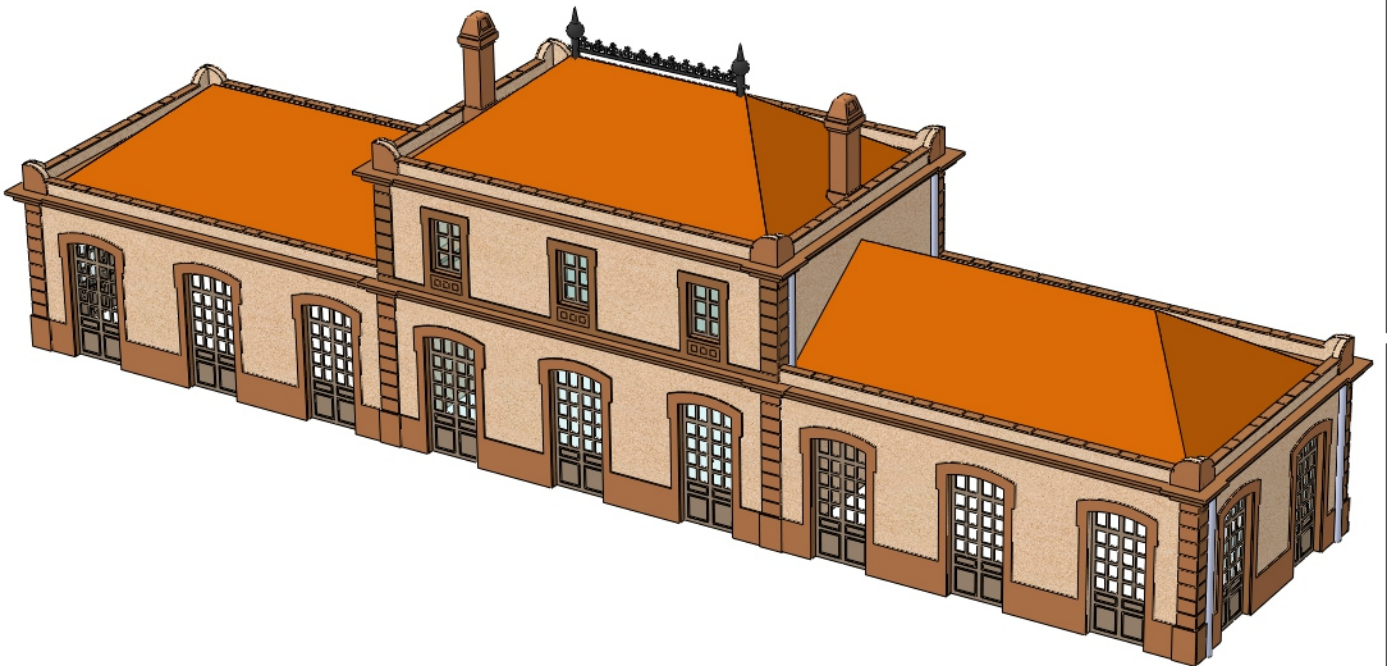

Estación de Sabiñánigo en escala H0

Planos

